

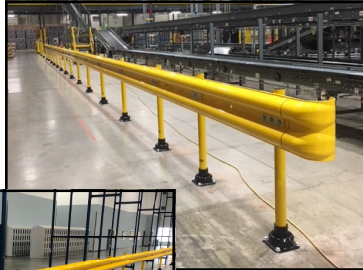

SlowStop® Type 1 Modular FlexRail (SS-T1Y-100-GRS)



45 Degree Impacts

MASS (KG)	1000	2000	3000	4000	5000	6000	7000	8000	9000	10000
SPEED (KPH)										
3.0	Green	Green	Green	Green	Green	Green	Green	Green	Green	Green
3.5	Green	Green	Green	Green	Green	Green	Green	Green	Green	Green
4.0	Green	Green	Green	Green	Green	Green	Green	Green	Green	Green
4.5	Green	Green	Green	Green	Green	Green	Green	Green	Yellow	Yellow
5.0	Green	Green	Green	Green	Green	Green	Green	Yellow	Yellow	Yellow
5.5	Green	Green	Green	Green	Green	Green	Yellow	Yellow	Yellow	Yellow
6.0	Green	Green	Green	Green	Yellow	Yellow	Yellow	Yellow	Yellow	Yellow
6.5	Green	Green	Green	Yellow	Yellow	Yellow	Yellow	Yellow	Yellow	Yellow
7.0	Green	Green	Yellow	Yellow	Yellow	Yellow	Yellow	Yellow	Yellow	Yellow
7.5	Green	Yellow	Yellow	Yellow	Yellow	Yellow	Yellow	Yellow	Yellow	Yellow
8.0	Green	Yellow	Yellow	Yellow	Yellow	Yellow	Yellow	Yellow	Yellow	Yellow
8.5	Green	Yellow	Yellow	Yellow	Yellow	Yellow	Yellow	Yellow	Yellow	Yellow
9.0	Green	Yellow	Yellow	Yellow	Yellow	Yellow	Yellow	Yellow	Yellow	Yellow
10.0	Green	Yellow	Yellow	Yellow	Yellow	Yellow	Yellow	Yellow	Yellow	Yellow

No Damage / Negligible Damage
Will Stop / Potential Damage to Guard
May Stop / Damage to Guard

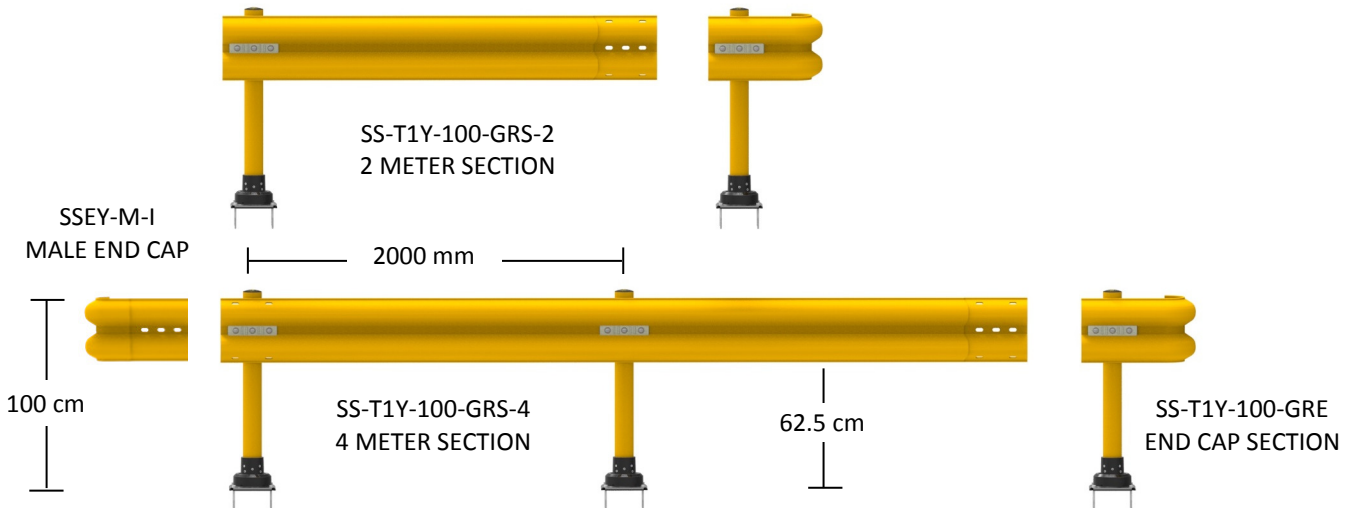

SPECIFICATIONS

- Includes Type 1 SlowStop Bollards—100cm tall
- Rail Break Strength: 110 kN
- Stopping Power Rating 15.458 Joules—45° Rail Impact
- Max deflection: 71 cm at break
- Temperature Rating: -40°C to 115°C
- Traffic Yellow (RAL 1023) Throughout
- No bending equipment required for curves (5m min. radius)
- Custom Heights Available

RECOMMENDED USES

- Light Duty
- Industrial Equipment Protection
- Pedestrian Aisle Ways
- Utility Guarding
- Access Denial
- Office Protection
- Computer Desks and Terminals
- Parking Perimeters



4955 Stout Dr. • San Antonio, TX 78219
 TEL: +1 (210) 736 4477 • FAX: +1 (210) 734 6448
 Email: info@slowstop.eu
www.slowstop.eu

