

# CARSTOPPER 30 (BSI PAS68:2010) V/1500(M1)/48/90:1.76/0.0

## PAS 68 Anti-Terrorist Low Cost Single Shallow Mount Removable Bollard



### Applications

- ▶ Airports
- ▶ Sports Arenas
- ▶ Retail Parks
- ▶ Police Stations
- ▶ Critical Infrastructure
- ▶ Government Buildings
- ▶ Conference Centres

*'Shallow mount foundation...  
Only 200mm deep single  
removable bollard!'*

### CARSTOPPER 30 (Low cost single shallow mount removable bollard)

Carstopper 30 is a shallow mount single removable bollard. This new patent pending design is a technology break-through in shallow mount single removal bollard. This can be fitted in a single or long runs, it is the only 200 deep single removable car park bollard in the market to date. It is an ideal solution to protect the retail shops, banks, sports stadiums, cash machine (atm's) and all accidental impacts.

**This bollard is an ideal anti-ram bollard solution. It is tested for Anti-terrorist protection, giving you the highest specification available. (See DVD)**

On low impacts the spring bollard will not need replacing as it will return to its original position. The shallow foundation will reduce the need to re-divert utilities. The system is small and easy to install keeping installation cost low. Once fitted and covered with a stainless steel shroud it is aesthetically pleasing and will need no maintenance, for access to maintenance area the bollard can be removed easily.

#### CARSTOPPER 30 PAS68 VEHICLE PERFORMANCE CLASSIFICATION

Vehicle Test Weight	Vehicle Class	Vehicle Speed	Vehicle Angle	Vehicle Penetration	25KG+ Dispersion
V/1500 KG	M1	48	90	1.76	0.00

# CARSTOPPER 30 (BSI PAS68:2010) V/1500(M1)/48/90:1.76/0.0

## PAS 68 Anti-Terrorist Low Cost Single Shallow Mount Removable Bollard



### Product Specification:

Height Above Ground: 850mm

Width: 73mm

Footing Depth: Only 200mm

Options: Stainless Steel or Mild Steel Shroud

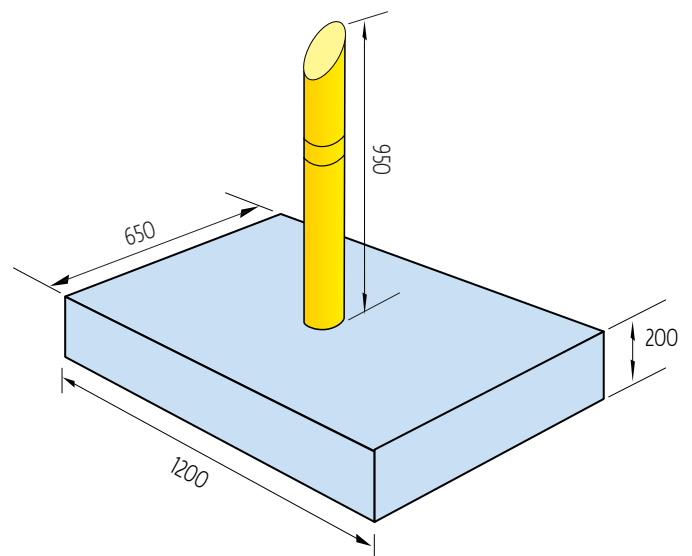

**safetyflex**  
ANTI TERRORIST BARRIERS  
[www.safetyflexbarriers.com](http://www.safetyflexbarriers.com)

Safetyflex Barriers  
Boston Place, Coventry UK CV6 5NN  
UK Sales Tel: +44 (0) 2476 664911 Fax: +44 (0) 2476 663020  
Export Sales Tel: +44 (0) 2476 688447 E-mail: [sales@safetyflexbarriers.com](mailto:sales@safetyflexbarriers.com)