

# TRUCKSTOPPER 1 (BSI PAS68:2010) V/7500/N2/48/90/0.00/0.00

## PAS 68 Anti-Terrorist Spring Bollard System



### Applications

- ▶ Airports
- ▶ Military Bases
- ▶ Perimeter Security HVM

### TRUCKSTOPPER 1

TRUCKSTOPPER 1 has been successfully tested at MIRA to BSI PAS68:2007 with a 7.5 tonne truck at 30mph (48km/h) resulting in zero penetration. The barrier can follow the contour of the ground and follows corners as the hinged barrier front can turn 360 degrees with no special parts. Once fitted it needs no ongoing adjustment or tensioning of the barrier and the steel is good for 20 year wear, with the only need for re-painting. This unique long life spring barrier system provides a heavy duty flexibility that will withstand extreme forces from high impact collision.

*'Achieves zero penetration status with a footing of only 400mm deep and 1.2 metres wide'*

TRUCKSTOPPER 1 PAS68 VEHICLE PERFORMANCE CLASSIFICATION					
Vehicle Test Weight	Vehicle Class	Vehicle Speed	Vehicle Angle	Vehicle Penetration	25KG+ Dispersion
V/7500 KG	N2	48	90	0.00	0.00

# TRUCKSTOPPER 1 (BSI PAS68:2010) V/7500/N2/48/90/0.00/0.00

## PAS 68 Anti-Terrorist Spring Bollard System



### Safetyflex solutions include:

- ▶ Flexibility to design to your requirements
- ▶ Manufacture of bespoke and one off products
- ▶ On-site management and installation
- ▶ Street furniture available on PAS rated spring bollards
- ▶ Car Park Spring barriers tested to BS6399 and BS1680

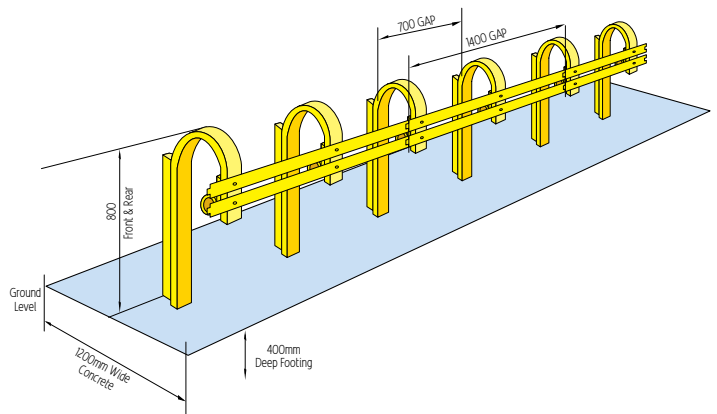

**safetyflex**  
ANTI TERRORIST BARRIERS  
[www.safetyflexbarriers.com](http://www.safetyflexbarriers.com)

Safetyflex Barriers  
Boston Place, Coventry UK CV6 5NN  
UK Sales Tel: +44 (0) 2476 664911 Fax: +44 (0) 2476 663020  
Export Sales Tel: +44 (0) 2476 688447 E-mail: [sales@safetyflexbarriers.com](mailto:sales@safetyflexbarriers.com)